

LED light by cep

"CEP PRO" Led Lamp  
Ref. Cled-0100



Description

Fun and contemporary lines.  
Flexibility through up / down movement of the arm and 360° rotation of the head. 3w LED COB.  
Touch switch with dimmer.  
Extra-thin base to save desk space - ideal for small workspaces.  
Perfect stability.  
Structure : 100% recyclable steel and aluminum.  
Dim : H8 Ø150 mm  
**Colour rendering index (CRI): >80**  
**Intensity dimmer : Max 255 Lumen.**  
**Lifespan : 50 000h.**  
**Light beam Cm/Lux : 30 cm / 830 Lux.**  
**Colour temperature (Kelvin) : 3000°K±10%.**  
**Power on (PonMax) : 4,92 W.**  
- Base: painted steel; round shape; nonslip protection;  
- Foot: anodized aluminium with steel core ; H300 Ø16mm  
- Articulation: 1 chromium plated articulation for up/down adjustment; 360° axial rotation of the head  
- Head: anodized aluminium; extra light ; chromium plated aluminium top ; jack connector ; L285 Ø16mm  
This luminaire contains a Class G source. Compact box for reduced CO2 impact. Power supply: 230V standard power cable.

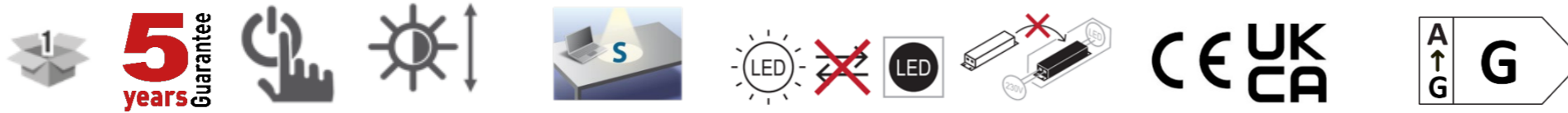
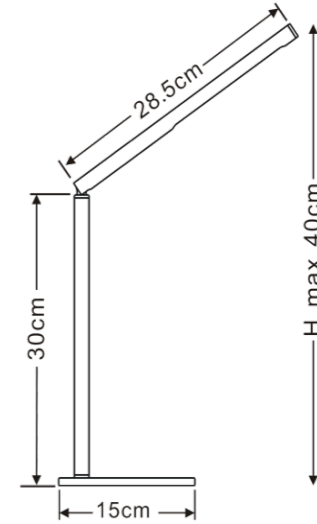

Available references

Ref.	Cep Code	Barcode unit	Barcode box	Gencod cardboard	Barcode Pallet
Cled-0100 Black base / Metal grey arms	2004000301	3462151000969	3462159000114	NC	NC

Customs number

94052140

Logistical data

PRODUCT			BOX				CARDBOARD				PALLET			
Ref.	Dimensions mm	Weight Unit. Kg	PCB	Dimensions mm	Gross Weight kg	Net Weight kg	PCB	Dimensions mm	Gross Weight kg	Net Weight kg	PCB	Dimensions mm	Gross Weight kg	Net Weight kg
CLED-0100	150xØx400	1,35	1	350x230x45	1,55	NC	8	480x360x200	12,9	NC	432	1200x800x2200	707	NC

